

Data Sheet Sampling Valves

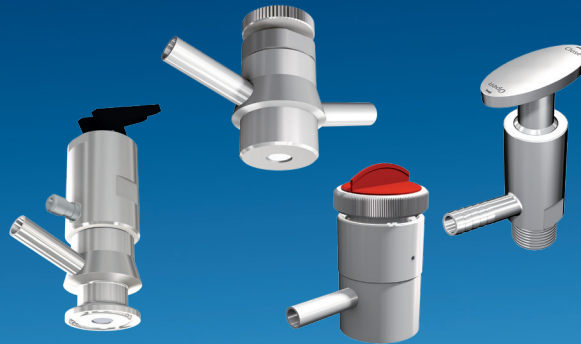

Hygienic Sampling Valve



We make hygiene affordable. This is now also backed up by the enhanced AWH sampling valve. When it comes to determining taste, appearance, and microbiological and chemical values, taking accurate samples is paramount.

Our hygienic sampling valve was developed specifically for these applications. Its very good cleanability was confirmed by the EHEDG in 2016. This means your products will not be contaminated when used properly.

The new AWH sampling valve comes in four different versions with a variety of connection types for a wide range of applications: whether in the weld-in, weld-on, screw-in, or clamp-socket version. An optional rinsing connection can be attached for all versions.

Sampling Valve manually operated with Male Part Adapter



Rinsing and sample connections are optionally available with locking caps and chain. All manually operated variants are also available with a lockable handwheel to protect against unauthorized access. The current AWH valve catalog has a wide range of options available.

Sampling Valve manually operated and lockable with closure cap for sealing into a container.

Technical Data

Material:	contact with product: 1.4404 (316L)
Surfaces:	contact with product: Ra ≤ 0.8 µm
Operating pressure:	max. 10 bar / 145 psi
Permissible operating temperature:	max. 80 °C / 176 °F CIP cleaning up to 90 °C / 194 °F max. unswitched, short-term 30 min. SIP cleaning up to 135 °C / 275 °F max. unswitched, short-term 30 min.
Actuation:	manual/optional lockable
Seal ring:	PTFE bellow
Product sampling:	DN8 (10 x 1 mm) pipe, others upon request
Steam rinse port:	DN8 (10 x 1 mm) pipe optional, others upon request

Pneumatic Sampling Valve



With the hygienic, pneumatic compact air sampling valve, there is also an automatic sampling system with additional manual actuation in the AWH portfolio.

The sampling valve has a clamp connection in accordance with DIN 32676 and is compatible with the AWH Connect tank connection flange system. Our design is based on the tried-and-tested hygienic sampling valve with manual operation.

Upon request, an optional flushing connection can be attached for this version. This means that a connection to an automated CIP/SIP system is possible. In addition to the various predefined versions in the AWH sampling portfolio, customer-specific solutions can also be implemented.

Pneumatic sampling valve



Pneumatic sampling valve connected to AWH-Connect

Technical Data

Material:	contact with product: 1.4404 (316L)
Surfaces:	contact with product: Ra ≤ 0.8 µm
Operating pressure:	max. 8 bar / 116 psi
Permissible operating temperature:	max. 80 °C / 176 °F CIP cleaning up to 90 °C / 194 °F max. unswitched, short-term 30 min. SIP cleaning up to 135 °C / 275 °F max. unswitched, short-term 30 min.
Activity:	Pneumatically and manual
Seal Ring:	PTFE bellow
Product sampling:	DN8 (10 x 1 mm) pipe, others upon request
Steam rinse port:	DN8 (10 x 1 mm) pipe optional, others upon request
Connection:	clamping piece in accordance with DIN 32676 Plate diameter 25 mm/34 mm

Vario Sampling Valve



The AWH Vario version is a sampling valve that can take product samples in two ways. Firstly, in the conventional way using the sampling tube;

In addition, by means of a cannula, which is pushed through the membrane to take samples via a syringe or tube. The multiple-use membrane automatically closes when the cannula is withdrawn. Contamination from outside is thus reduced to a minimum.

Sampling valve Vario DN40 weldon

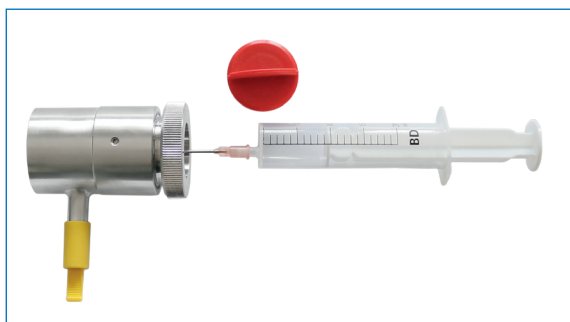

Sampling valve Vario DN40 weldon with syringe

Technical Data

Material:	contact with product: 1.4404 (316L)
Surfaces:	contact with product: Ra ≤ 0.8 µm
Operating pressure:	max. 4 bar / 58 psi
Sampling with a cannula:	max. 2 bar / 29 psi (Please read carefully the chapter "Sampling by cannula" in the operating instructions.)
Permissible operating temperature:	max. 80 °C / 176 °F CIP cleaning up to 90 °C / 194 °F max. unswitched, short-term 30 min. SIP cleaning up to 135 °C / 275 °F max. unswitched, short-term 30 min.
Seal ring:	Membrane: EPDM, FKM and silicone
Product sampling:	DN8 (10 x 1 mm) pipe, others upon request
Connections:	Welded version for pipe DN15 (19 x 1.5 mm) Welded version for pipe DN40 (41 x 1.5 mm) External thread R 1/2"

ECO Sampling Valve



The AWH ECO version is the economical entry into the AWH product portfolio. Suitable for product sampling of fluids from tanks and pipelines in systems of the food and beverage industry. The sampler is available in screw-in and weldon versions. It is sealed with a PTFE stopper that closes near the product.

ECO sampling valve with R 1/2" external thread

Technical Data

Material:	contact with product: 1.4404 (316L)
Surfaces:	contact with product: Ra ≤ 0.8 µm
Operating pressure:	max. 10 bar / 145 psi
Permissible operating temperature:	max. 80 °C / 176 °F CIP cleaning up to 90 °C / 194 °F max. unswitched, short-term 30 min. SIP cleaning up to 135 °C / 275 °F max. unswitched, short-term 30 min.
Actuation:	manual
Seal ring:	plugs: PTFE, O-Ring: EPDM
Product sampling:	Hose connection (OD 10 mm) Inside diameter approx. 6.5 mm
Connections:	Welded version for pipe DN15 (29 x 1.5 mm) External thread R 1/2"



Armaturenwerk Hötensleben GmbH
Schulstr. 5-6
D-39393 Hötensleben

Tel: +49 39405 92-0
Fax: +49 39405 92-111
E-Mail: info@awh.eu
<http://www.awh.eu>

NEUMO Ehrenberg Group

