

Fittings

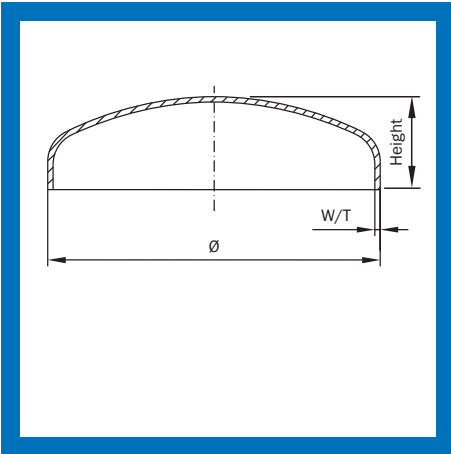

End Caps

Size mm (inch)	\emptyset	W/T	Height	Weight [kg]			AISI 316L Matt	AISI 316L Satin
							Article No.	Article No.
25.4	25.4	1.6	12	0.015				34565
38.1	38.1	1.6	15	0.029				34566
50.8	50.8	1.6	19	0.055				34567
63.5	63.5	1.6	19	0.076				34568
76.1	76.1	1.6	27	0.097				34569
101.6	101.6	2	24	0.187				34570
104	104	2	24	0.187			18252	
129	129	2	34	0.314			18253	
154	154	2	41	0.444			18254	
204	204	2	50	0.754			18255	

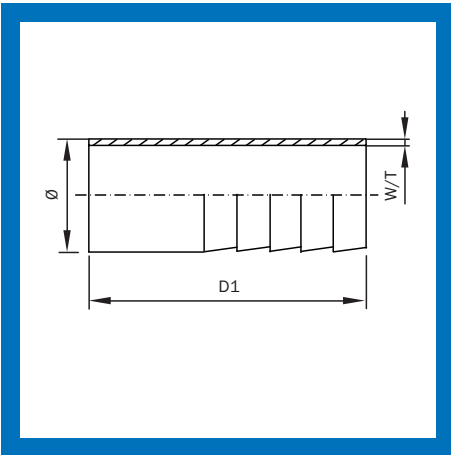

Weld Hose Tail

Size mm (inch)	\emptyset	W/T	Length	Weight [kg]				AISI 316L Satin
								Article No.
25.4	25.4	1.6	30	0.03				53412
38.1	38.1	1.6	30	0.04				53413
50.8	50.8	1.6	36	0.07				53414
63.5	63.5	1.6	37	0.09				53415
76.1	76.1	1.6	56	0.17				53416
101.6	101.6	2	63	0.32				53417

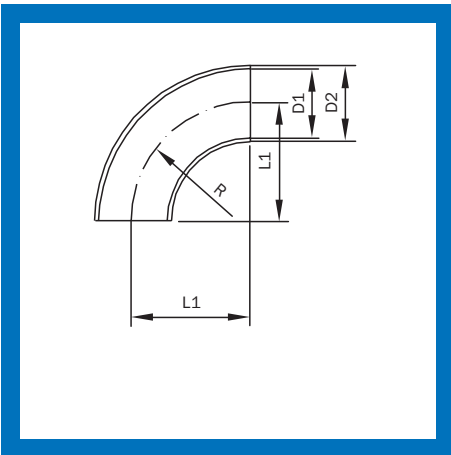

Bend 90° DIN 11852

Size mm DN	D1	D2	L1	R	Weight [kg]	AISI 304L Matt	AISI 304L Satin	AISI 316L Matt	AISI 316L Satin
						Article No.	Article No.	Article No.	Article No.
10	9	12	26	26	0.01	40033	41033	50033	51033
10	10	13	26	26	0.01	40034	41034	50034	51034
15	15	18	35	35	0.02	40035	41035	50035	51035
15	16	19	35	35	0.02	40036	41036	50036	51036
20	19	22	40	40	0.04	40037	41037	50037	51037
20	20	23	40	40	0.04	40038	41038	50038	51038
25	25	28	50	50	0.05	40039	41039	50039	51039
25	26	29	50	50	0.05	40040	41040	50040	51040
32	31	34	55	55	0.08	40041	41041	50041	51041
32	32	35	55	55	0.08	40042	41042	50042	51042
40	37	40	60	60	0.10	40043	41043	50043	51043
40	38	41	60	60	0.10	40044	41044	50044	51044
50	49	52	70	70	0.17	40045	41045	50045	51045
50	50	53	70	70	0.17	40046	41046	50046	51046
65	66	70	80	80	0.39	40047	41047	50047	51047
80	81	85	90	90	0.57	40048	41048	50048	51048
100	100	104	100	100	1.17	40049	41049	50049	51049
125	125	129	187.5	187.5	1.90	40050	41050	50050	51050
150	150	154	225	225	2.72	40051	41051	50051	51051
200	200	204	300	300	4.75	40052	41052	50052	51052